

PART NUMBER # 313-1001										
DESCRIPTION: COMPLETE ASSY										
QTY: X										
MATERIAL: X										
PC	PR	LC	MA	SF	WD	\$				

THIS DRAWING IS © COPYRIGHT AND IS THE PROPERTY OF TIDD ROSS TODD LTD. IT IS FURNISHED TO YOU FOR CONFIDENTIAL INFORMATION PURPOSES ONLY AND IS NOT TO BE DISCLOSED TO ANYONE ELSE OR USED FOR MANUFACTURING PURPOSES WITHOUT THE EXPRESS WRITTEN PERMISSION OF TIDD ROSS TODD LTD.

TOLERANCE : ± 0.5mm UNLESS OTHERWISE STATED		
WIRE BUFF ALL STEEL COMPONENTS PRIOR TO WELDING		
WELDING : ALL INFORMATION SHALL COMPLY WITH NZ/AS 1554:2000 PT 1 CATEGORY SP UNLESS OTHERWISE STATED AND SHALL BE WELDED TO A QUALIFIED PROCEDURE, BY A WELDER QUALIFIED FOR THE APPROPRIATE POSITION AND SUPERVISED BY A WELDING SUPERVISOR		
REV	DATE	COMMENT



**48 Maui Street
Hamilton
New Zealand**
Phone +64 7 849 4839
Fax +64 7 849 3628
Email : trt@trt.co.nz
ISO 9001

NAME	DATE	TITLE:
DRAWN RJC	03/07/2018	COMPLETE ASSY ~ GENERAL ASSEMBLY (G.A)
CHK'D -	-	
APPV'D -	-	

SHEET 1 OF 2	DWG NO.	REVISION
SCALE:1:100	313-1001	A

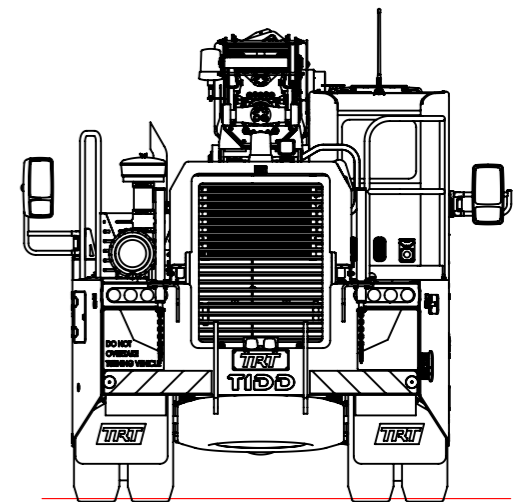
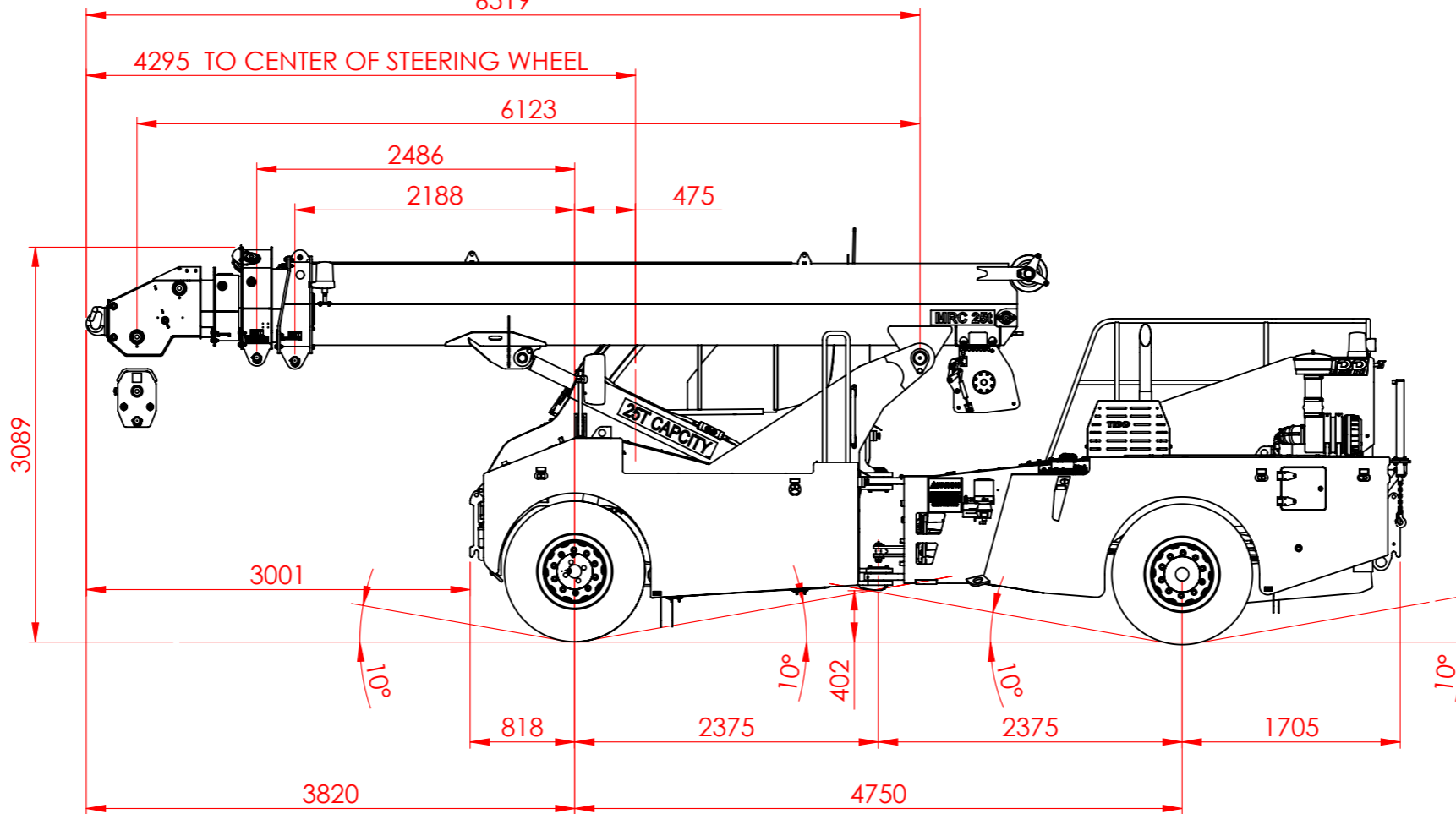
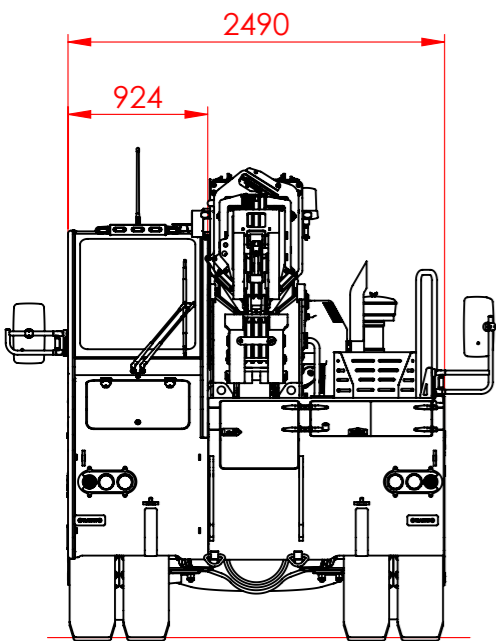
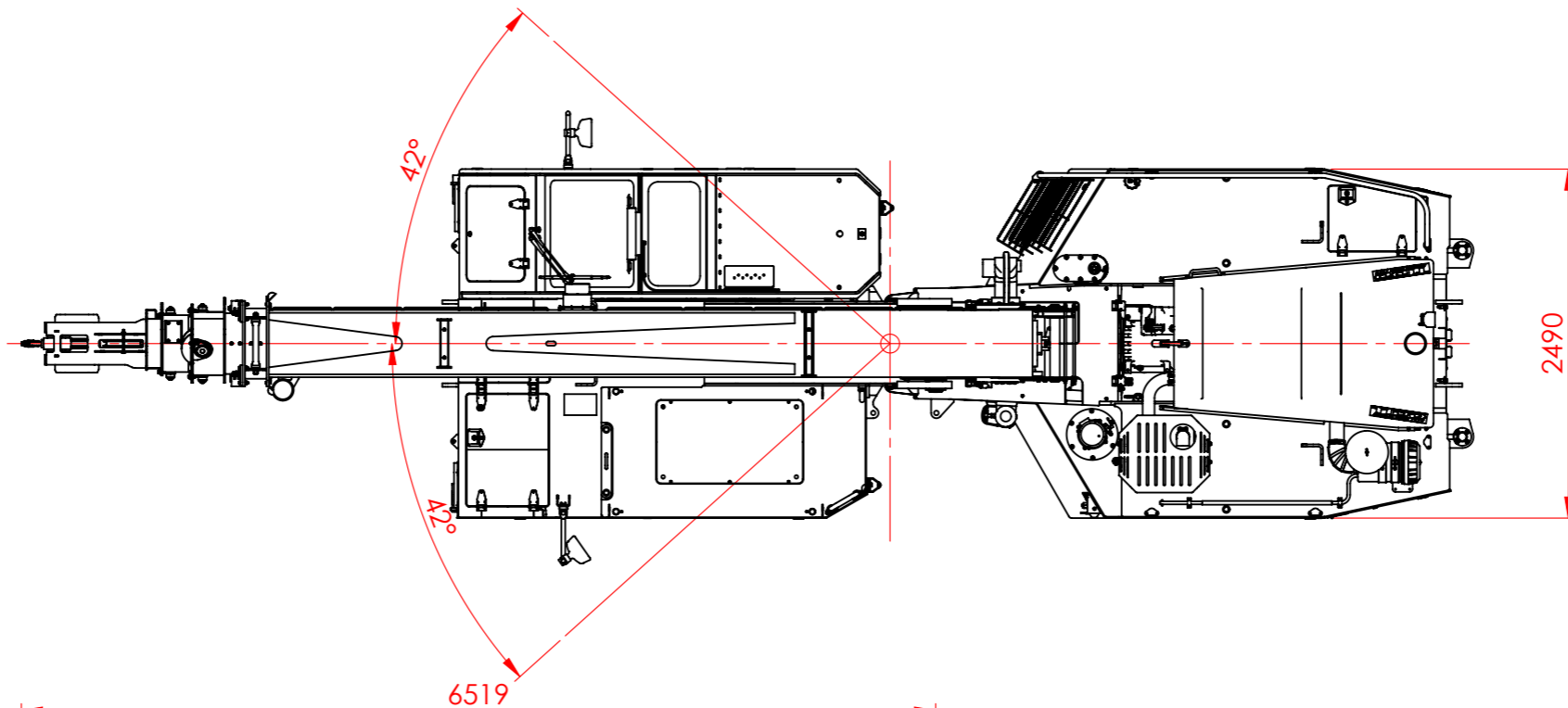

TYRES = 12.00 R20 20 PLY
ROAD SPEED 80km/hr

TOLERANCE : ± 0.5mm UNLESS OTHERWISE STATED
WIRE BUFF ALL STEEL COMPONENTS PRIOR TO WELDING

THIS DRAWING IS © COPYRIGHT AND IS THE PROPERTY OF TIDD ROSS TODD LTD. IT IS FURNISHED TO YOU FOR CONFIDENTIAL INFORMATION PURPOSES ONLY AND IS NOT TO BE DISCLOSED TO ANYONE ELSE OR USED FOR MANUFACTURING PURPOSES WITHOUT THE EXPRESS WRITTEN PERMISSION OF TIDD ROSS TODD LTD.

WELDING: ALL INFORMATION SHALL COMPLY WITH NZ/AS 1554:2000 PT 1 CATEGORY SP UNLESS OTHERWISE STATED AND SHALL BE WELDED TO A QUALIFIED PROCEDURE, BY A WELDER QUALIFIED FOR THE APPROPRIATE POSITION AND SUPERVISED BY A WELDING SUPERVISOR

REV	DATE	COMMENT	NAME



48 Maui Street
Hamilton
New Zealand
Phone +64 7 849 4839
Fax +64 7 849 3628
Email : trt@trt.co.nz
ISO 9001

	NAME	DATE
DRAWN	RJC	03/07/2018
CHK'D	-	-
APPV'D	-	-

DO NOT SCALE DRAWINGS IN mm's

TITLE:	
COMPLETE ASSY ~ GENERAL ASSEMBLY (G.A)	
SHEET 2 OF 2	DWG NO. 313-1001
SCALE:1:50	REVISION A

REVISION
A